

MAXIM

MAX1605 Evaluation Kit

Evaluates: MAX1605

General Description

The MAX1605 evaluation kit (EV kit) is a fully assembled and tested surface-mount circuit board that contains a boost switching converter that generates a positive voltage to drive low-power LCD displays. The circuit is configured for a +18V output voltage and provides up to 30mA. Higher output voltages are possible by selecting different components.

The IC operates from a +2.4V to +5.5V supply voltage but can boost battery voltages as low as +0.8V up to +30V at the output. Three different inductor current limits can be evaluated with the EV kit as configured.

The MAX1605 EV kit demonstrates low quiescent current and high efficiency up to 88% for maximum battery life. Operation up to 500kHz allows the use of tiny surface-mount components.

Component List

DESIGNATION	QTY	DESCRIPTION
C1	1	0.1 μ F, 16V, X7R ceramic cap (0603) Taiyo Yuden EMK107BJ104KA
C2, C3	2	1.0 μ F, 25V, X7R ceramic caps (1206) Taiyo Yuden TMK316BJ105KL
C4	1	10pF, 50V ceramic cap (0603) Taiyo Yuden UMK107CG100DZ
D1	1	500mA, 30V Schottky diode (SOD-123) Nihon EP05Q03L or Toshiba CRS02
L1	1	10 μ H, 700mA inductor Sumida CR32-100
R1	1	2.2M Ω \pm 1% resistor (0805)
R2	1	165k Ω \pm 1% resistor (0805)
U1	1	MAX1605EUT (6-pin SOT23)
JU1, JU2	2	3-pin headers
None	2	Shunts (JU1, JU2)
None	1	MAX1605 PC board
None	1	MAX1605 data sheet
None	1	MAX1605 EV kit data sheet

Features

- ◆ **Input Voltage**
 - +0.8V to +18V (as configured)
 - +2.4V to +5.5V (IC V_{CC})
- ◆ **Output Voltage**
 - +18V Output Up to 30mA (as configured)
- ◆ **Output Voltage Adjustable with Resistors**
- ◆ **Adjustable Inductor Current-Limit Setting**
- ◆ **Internal MOSFET Switches**
- ◆ **1 μ A (typ) IC Shutdown Current**
- ◆ **Switching Frequency Up to 500kHz**
- ◆ **Surface-Mount Components**
- ◆ **Fully Assembled and Tested**

Ordering Information

PART	TEMP. RANGE	IC PACKAGE
MAX1605EVKIT	0°C to +70°C	6 SOT23-6

Component Suppliers

SUPPLIER	PHONE	FAX
Nihon USA	661-867-2555	661-867-2698
Sumida	847-956-0666	847-956-0702
Taiyo Yuden	408-573-4150	408-573-4159
Toshiba	949-455-2000	949-859-3963

Note: Please indicate that you are using the MAX1605 when contacting these component suppliers.

Quick Start

The MAX1605 EV kit is fully assembled and tested. Follow these steps to verify board operation. **Do not turn on the power supply until all connections are completed.**

- 1) Connect a +0.8V to +18V DC power supply to the VIN pad. Connect the supply ground to the GND pad (or use the same supply and limits as in step 2).
- 2) Connect a +2.4V to +5.5V DC power supply to the VCC pad. Connect the supply ground to the GND pad.
- 3) Verify that shunts are across pins 1 and 2 of jumpers JU1 (SHDN) and JU2 (LIM, 500mA).

MAX1605 Evaluation Kit

- 4) Turn on the VCC power supply, followed by the VIN power-supply. Power-supply sequencing is not critical.
- 5) Verify that the output (VOUT) is +18V.

For instructions on selecting the feedback resistors for other output voltages, refer to the *Evaluating Other Output Voltages* section in this document.

Detailed Description

The MAX1605 evaluation kit (EV kit) is a fully assembled and tested surface-mount circuit board that contains a boost switching converter, generating +18V used to drive low power LCD displays. The circuit provides up to 30mA of current to the EV kit's output. Higher output voltages up to +30V are possible by selecting different feedback resistors.

Power for the converter circuit can be supplied from a +0.8V to VOUT DC source or a multiple-cell lithium-ion (Li+) battery. The IC requires a +2.4V to +5.5V DC source. The IC can also be powered from the converter's input supply if the input voltage is limited to between +2.4V and +5.5V.

Three different inductor current limits can be evaluated with the EV kit (125mA, 250mA, and 500mA) by changing a jumper position.

The MAX1605 EV kit demonstrates low quiescent current (18μA ICC operating current) and high efficiency up to 88% for maximum battery life.

Jumper Selection

Shutdown Mode

The MAX1605 EV kit features a shutdown mode that reduces the MAX1605 shutdown current to less than 0.1μA, thus preserving battery life. The 3-pin jumper, JU1, selects the shutdown mode for the MAX1605. Table 1 lists the selectable jumper options.

Table 1. Jumper JU1 Functions

SHUNT LOCATION	SHDN PIN	MAX1605 OUTPUT
1 and 2	Connected to VIN	MAX1605 enabled, VOUT = +18V (as configured)
2 and 3	Connected to GND	Shutdown mode, VOUT = VIN - VDIODE

Inductor Current Limit

The MAX1605 EV kit features options for evaluating several different inductor current limits.

The 3-pin jumper, JU2 selects the inductor current limit for the MAX1605 EV kit. Table 2 lists the selectable jumper options.

Table 2. Jumper JU2 Function

SHUNT LOCATION	LIM PIN	INDUCTOR CURRENT LIMIT
1 and 2	Connected to VCC	500mA
2 and 3	Connected to GND	125mA
None	Floating	250mA

Evaluating Other Output Voltages

Output

The MAX1605 EV kit's boost converter output (VOUT) is set to +18V by two feedback resistors (R1, R2). To generate output voltages other than +18V (+0.8V to +30V), select different voltage-divider resistors (R1, R2). Capacitor C3 must be rated for higher than VOUT. Refer to the *Setting the Output Voltages* section in the MAX1605 data sheet for instructions on selecting the resistors. The output voltage (VOUT) is determined by the following equation:

$$V_{OUT} = V_{FB}((R1/R2) + 1)$$

where $V_{FB} = 1.25V$.

Single-Supply Operation

VIN and VCC

The MAX1605 EV kit can be operated from a single power supply. To evaluate the EV kit with a single supply, connect a jumper wire from the VIN pad to the VCC pad. Connect a +2.4V (min) to +5.5V (max) power supply to the VIN or VCC pad.

MAX1605 Evaluation Kit

Evaluates: MAX1605

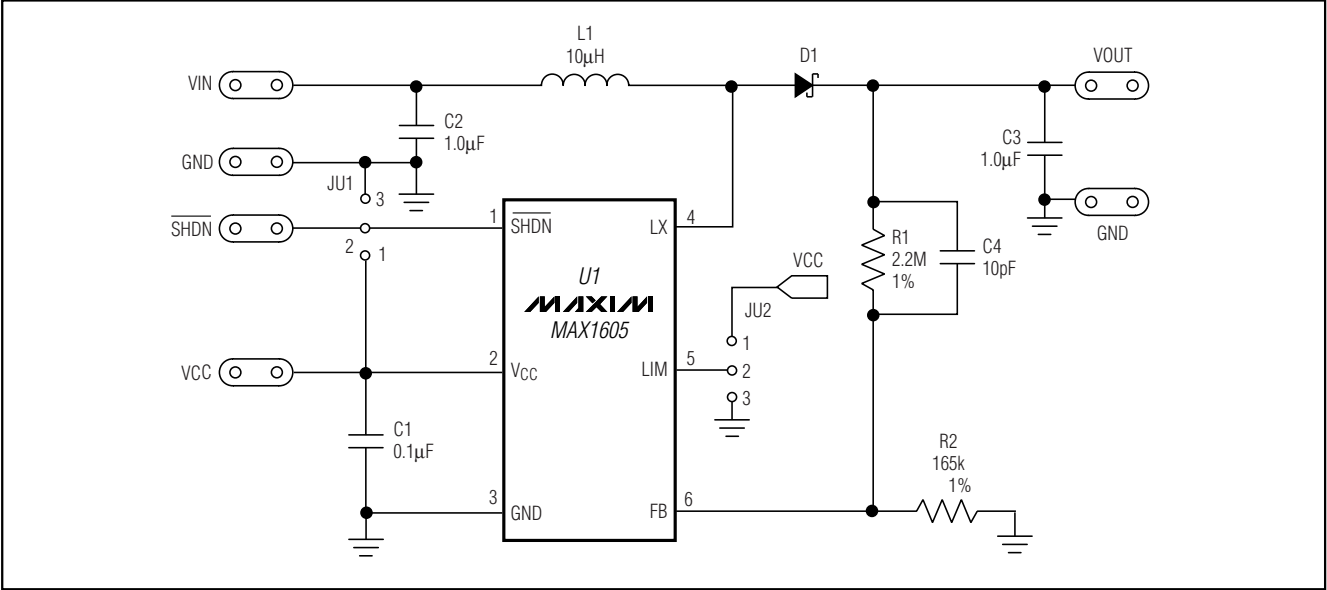

Figure 1. MAX1605 EV Kit Schematic

MAX1605 Evaluation Kit

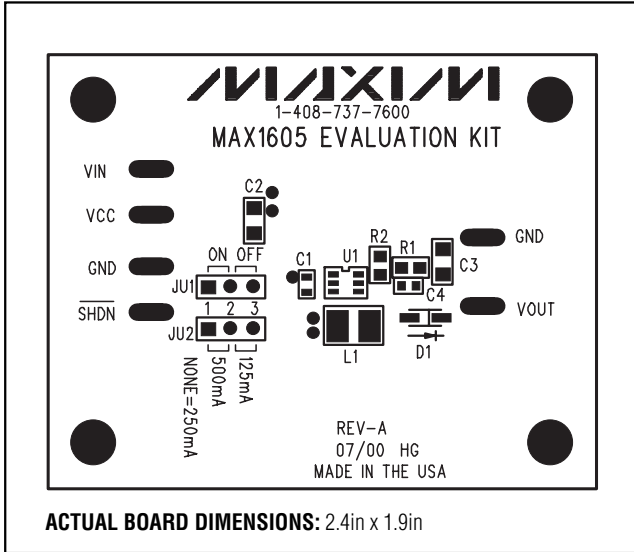

Figure 2. MAX1605 EV Kit Component Placement Guide—Component Side

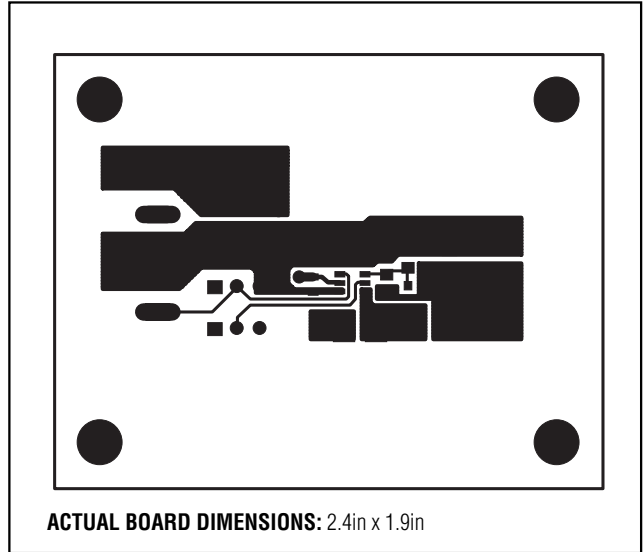

Figure 3. MAX1605 EV Kit PC Board Layout—Component Side

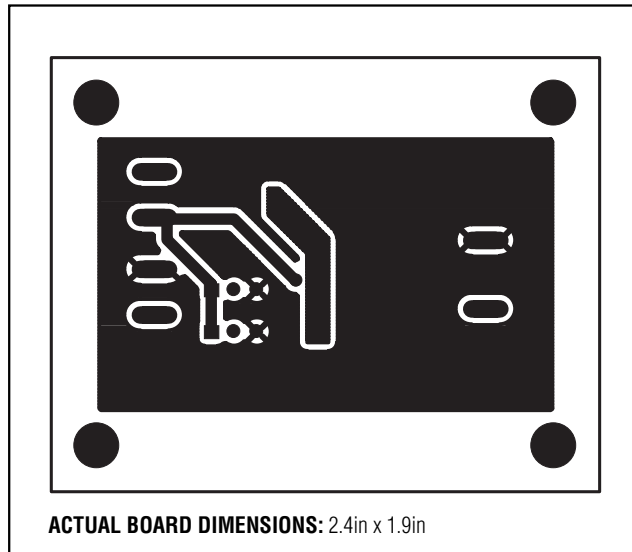

Figure 4. MAX1605 EV Kit PC Board Layout—Solder Side

Maxim cannot assume responsibility for use of any circuitry other than circuitry entirely embodied in a Maxim product. No circuit patent licenses are implied. Maxim reserves the right to change the circuitry and specifications without notice at any time.

4 _____ **Maxim Integrated Products, 120 San Gabriel Drive, Sunnyvale, CA 94086 408-737-7600**